

ALLUSION® BLIND SYSTEM WITH DOUBLE WAND OPERATION

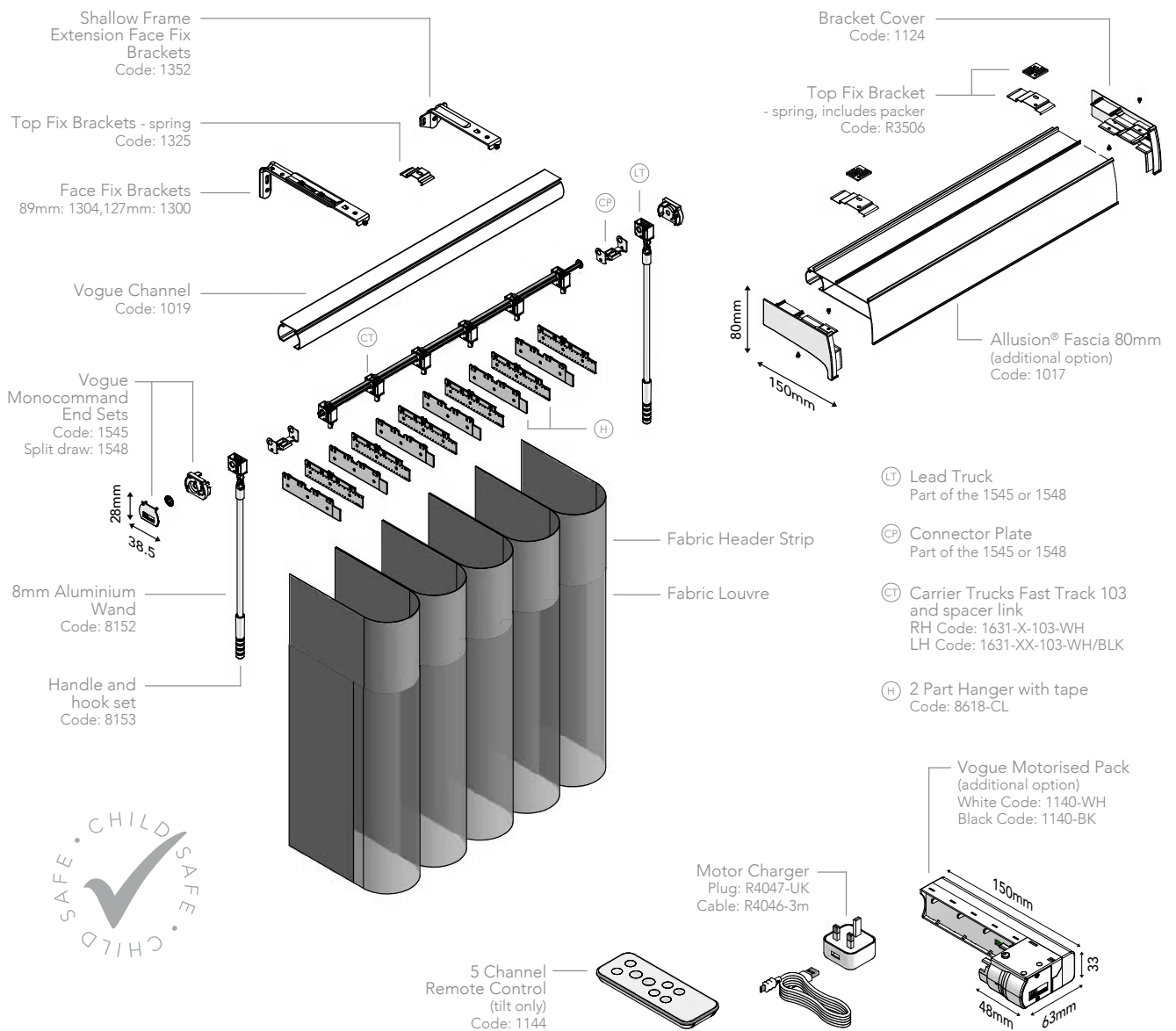

- Ideal for large windows and bifold or patio doors.
- With the doors open and the blind drawn closed, easily access the outside space by walking through the individual louvres.
- Filter daylight and retain the view.
- A robust and reliable, industry leading blind system, made of high quality plastic, stainless steel and aluminium with corrosion resistant finishes.
- 5m length (16'3") tracks available for wider windows and doors.
- Choose between the Allusion® Fascia or the sleek Louvolite Slimline® Vogue headrail.
- UV stabilised prime plastics used to guard against ultraviolet degradation.
- Can be used as room dividers to create sectioned spaces in hotel lobbys, restaurants or large conference rooms.
- Child safe operating wand option available.
- Using the Slimline® Vogue headrail, Allusion® can be motorised (tilt only) using Louvolite One Touch™ Vogue motorisation. Max 3m width. Motorisation not available with the Allusion® Fascia.
- Colours available: white, black and anthracite grey.

HARDWARE SPECIFICATION

Louvolute Allusion® Blind System

Allusion® Blinds are manufactured using the Louvolute Slimline Vogue® System with aluminium headrail 38.5mm x 28mm and include carrier trucks with UV stabilised self-aligning hooks. Operation is by tilt and draw monocommand wand control, cord & No 6 size chain or motorisation.

The tracks are smooth running and robust. The components are made from aluminium, prime plastic or stainless steel and minimise damage caused by operator misuse.

The brackets are made from

mild steel, zinc plated and powder coated and are suitable for top or face fixing.

A unique and optional 80mm fascia can be added, which offers the option of a matching fabric profile.

Headrail

The headrail extrusion and fascia are made from prime aluminium and powder coated to make it corrosion resistant.

Brackets are manufactured with a strengthening crease for increased strength and safety.

Carrier Trucks

Manufactured using prime

quality plastic materials, this ensures a positive and smooth operation while providing durability and protection from embrittlement and UV rays. Louvre hangers are manufactured using an optically transparent polycarbonate.

The gears in the carrier trucks that rotate the louvres are self-aligning with limit stops. This allows louvre rotation to 185°, enabling efficient closure without strain on the mechanism.

The spacing between the carrier trucks is controlled by high-grade stainless steel spacer links. The standard spacing is 103mm louvres.

Operation

Using manual or motorisation operation, all blinds must be compliant with the child safety elements of BS EN13120. Where children may be present, the chain must be fitted with cord tidy devices.

Maintenance

All Allusion® components for are manufactured using aluminium, plastic or stainless steel. They do not present any corrosion problems in normal environments. The system has been designed for smooth operation, together with a rigidity to prolong the window blind's working life.

BRACKET DIMENSIONS

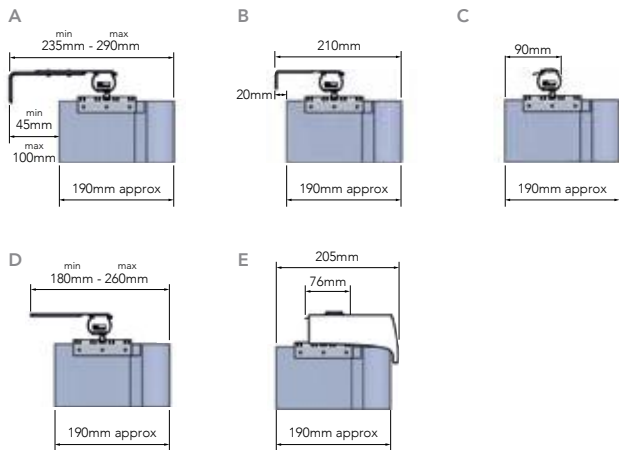

- A. 1340 adjustable face fix brackets
- B. 1352 shallow frame extension face fix brackets
- C. 1325 top fix brackets (spring)
1341: 130mm/230mm;
1351: 160mm/260mm
- D. Extension top fix brackets; 1342: 80mm/180mm;
- E. R3506 top fix bracket (spring) & packer (use with 1017)



BUNCHING OPTIONS AND STACKING DISTANCES

BUNCHING	ONE WAY	SPLIT	CENTRE
103mm (4") louvres	225mm (8¾") for 1st metre (3'3") width of blind. 175mm (7") for each additional metre	225mm (8¾") for 1st metre (3'3") width of blind. 175mm (7") for each additional metre	165mm (6½") for 1st metre (3'3") width of blind. 165mm (6½") for each additional metre

For the most up-to-date information view the online pdf at www.louvolutecommercial.com/systems/

Your Louvolute Allusion® Distributor:



CI/SIB 1976 reference by SIB Agency		
(76.7)	X	